

DESIGN FEATURES

- Built-in ISO 5211 Direct Mounting Pad Easy Automation
- Fire Safe Design Approved
- Anti-static Devices for Ball-Stem-Body
- Blow-out Proof Stem
- Pressure Balance Hole in Ball Slot
- TA-Luft Design Approved
- ISO 15848-1 Design Approved (Optional)
- NACE MR-0175 (Optional)
- Casting Approved by TUV AD 2000-Merkblatt W0
- Options : 1.Actuator 2.Limit 3.Positioner

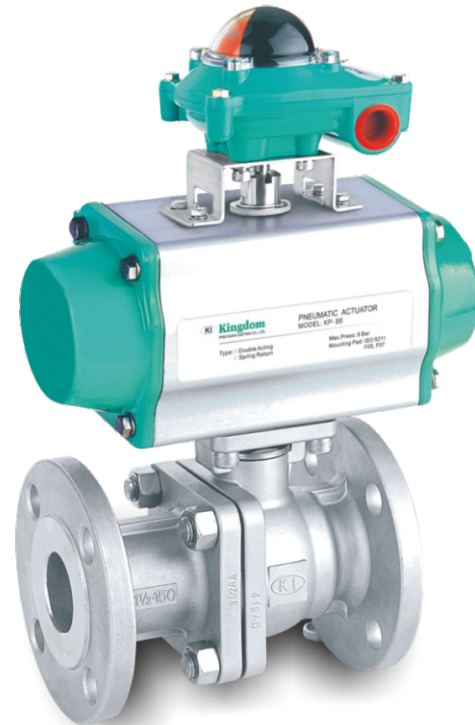

APPLICABLE STANDARDS

- Design Standard : ASME B16.34
- Frie Design : API 607 5th 2005, ISO10497
- Face To Face : ASME B16.10
- Flanged End : ASME B16.5 Class 150 / 300
- Inspection & Testing : API 598

CV VALUES

NPS	CV	
	Class 150	Class 300
1/2	18	18
3/4	36	36
1	48	48
1 1/4	93	93
1 1/2	165	165
2	207	207
2 1/2	450	450
3	780	780
4	1360	1360
5	1700	1700
6	2600	2600
8	4200	4200

WEIGHT

NPS	KV-L41/KV-L61		KV-L42/KV-L62	
	Weight (kg)	Weight (lb)	Weight (kg)	Weight (lb)
1/2	1.6	3.5	2.54	5.60
3/4	2.3	5.1	3.64	7.94
1	3.0	6.6	4.55	9.92
1 1/4	3.5	7.7	5.17	11.4
1 1/2	5.6	12.4	8.69	19.2
2	8.4	18.5	10.9	24.1
2 1/2	14.5	32.0	17.5	38.6
3	18.5	40.8	27.3	59.5
4	29.5	65.0	41.8	92.2
5	53.5	118.0	67.6	149.1
6	74.0	163.0	100.6	221.8
8	128.0	282.0	144.3	318.2

TORQUE VALUES

Close to Open Torque at Various Differential Pressure (ΔP), Standard Seats (TFM1600&PTFE)

unit : in-lb / N-m

Size/ ΔP	75 psig		150 psig		300 psig		700 psig	
	5 bar		10 bar		20 bar		50 bar	
NPS	N-m	In-lb	N-m	In-lb	N-m	In-lb	N-m	In-lb
1/2	5	44	5	44	5	44	5	44
3/4	6	53	6	53	6	53	6	53
1	10	88	10	88	11	97	11	97
1 1/4	13	115	13	115	15	133	17	150
1 1/2	19	168	19	168	22	195	24	212
2	25	221	29	257	32	283	35	310
2 1/2	40	354	45	398	49	434	54	478
3	65	575	72	637	81	717	90	796
4	100	885	110	973	122	1080	135	1195
5	190	1681	210	1858	245	2168	285	2522
6	280	2478	306	2708	340	3009	530	4690
8	487	3274	430	3805	487	4310	760	6726

- Remark : 1.Torques will increase about 30% if seat materials are Reinforced Fiber-Glass PTFE, Carbon-filled. PTFE or EK+PTFE or EK+PTFE or TFM4215.
- 2.The torque figures at 5 bar pressure are maximum values to be tested after the valves are placed for 24 hours.
- 3.For actuator sizing, a safety factor of minimum 30% is recommended.

TECHNICAL INFORMATION

PRESSURE - TEMPERATURE DATA

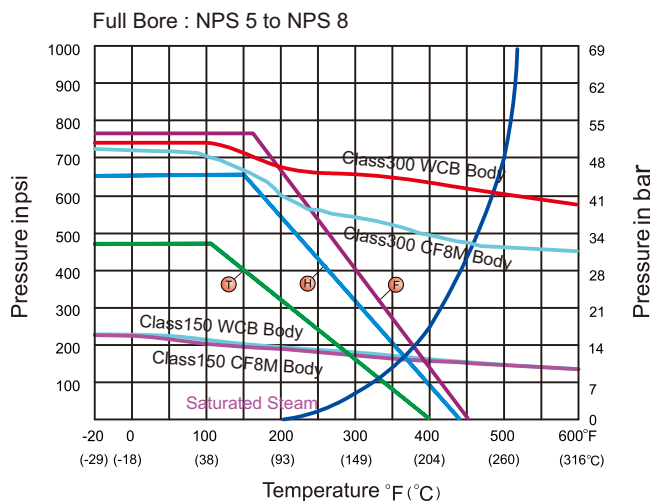
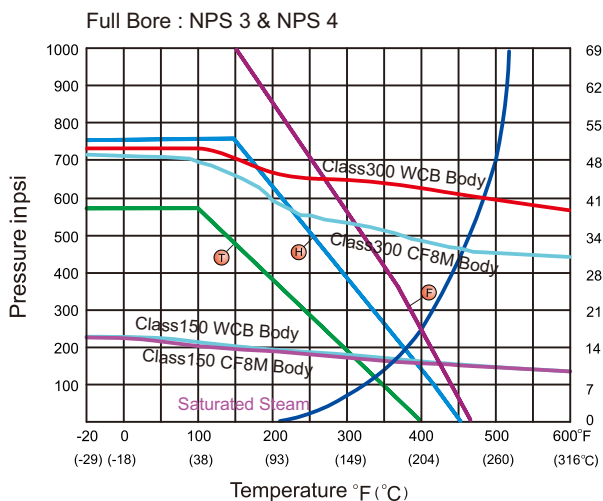
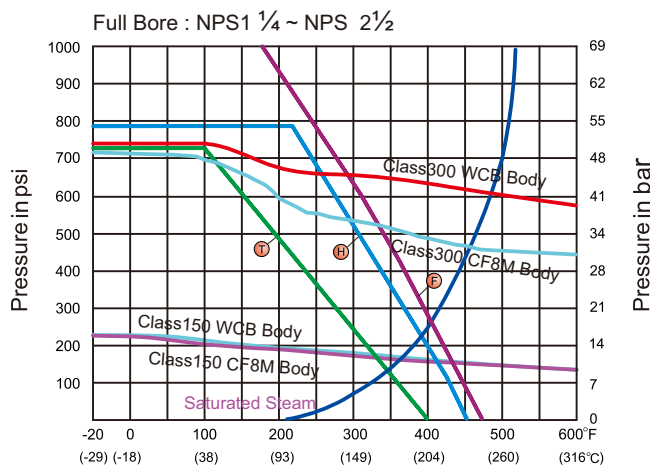
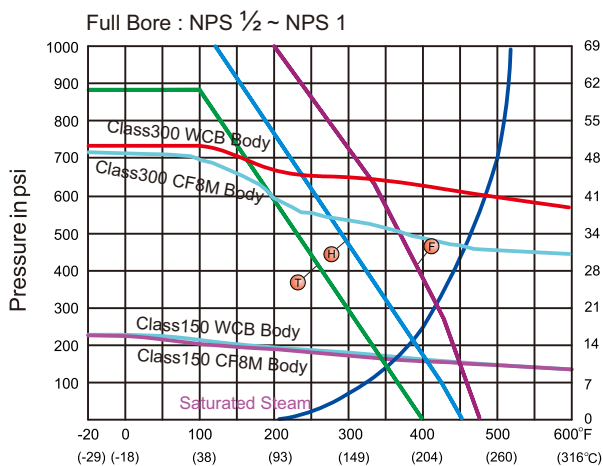

Seat Materials : T PTFE B TFM1600 E TFM4215

The pressure-temperature data of ball valves are determined, not only by valve shell materials, but also by sealing materials used for ball seats, gland packings, and flange gaskets

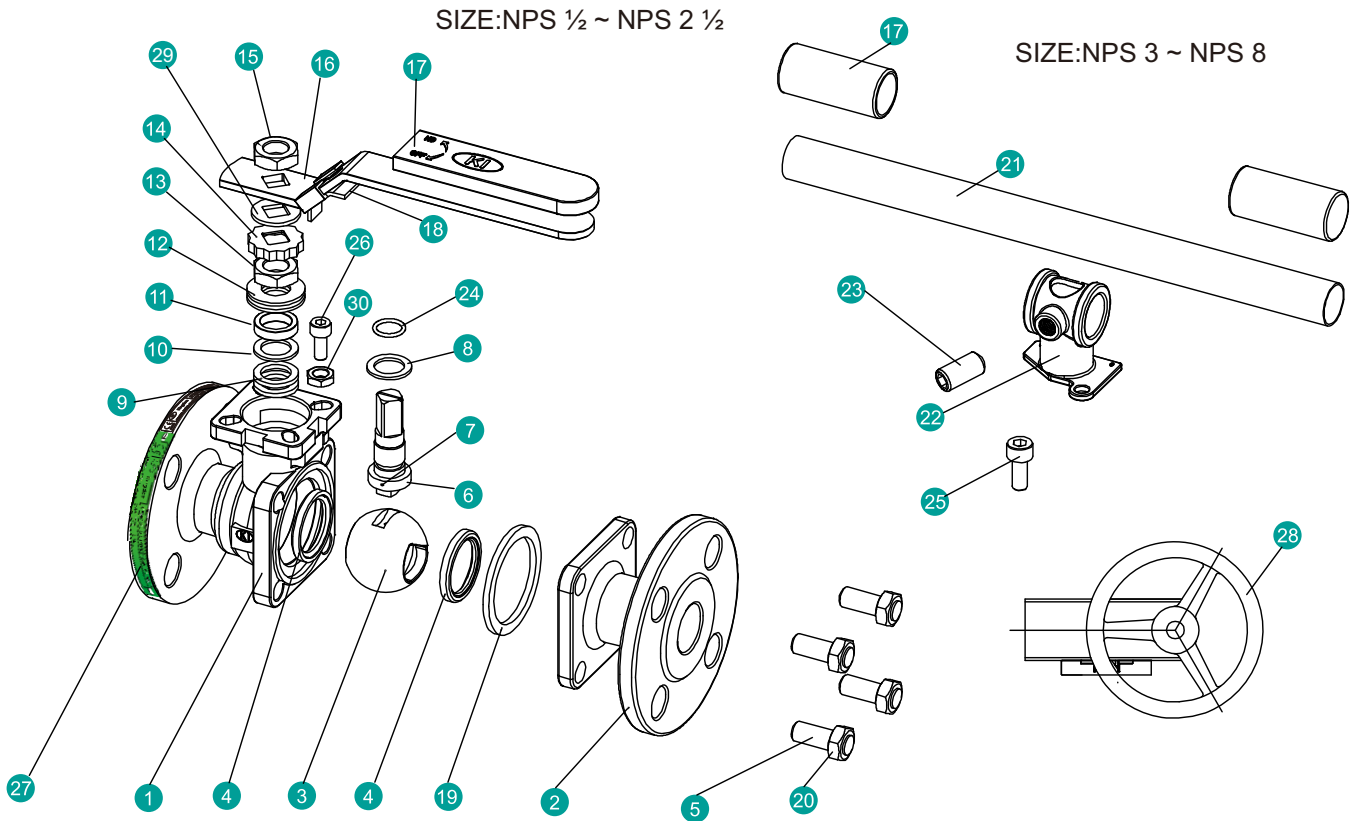

MATERIAL OF CONSTRUCTION

NO.	PART NAME	MATERIALS		
		ANSI	ANSI	ANSI
1	End Cap	A351-CF8M	A351-CF8	A216-WCB
2	Body	A351-CF8M	A351-CF8	A216-WCB
3	Ball	A351-CF8M	A351-CF8	
4	Ball Seat	TFM1600 / PTFE / TFM4215		
5	Bolting	A193-B8		A193-B7
6	Stem	316	304	
7	Anti-Static	316	304	
8	Thrust Washer	PTFE/TFM1600		
9	Stem Packing	PTFE / GRAFOIL*		
10	Bushing	50%SS+50%PTFE / 304*		
11	Gland	316		
12	Belleville Washer	301		
13	Stem Nut	A194-8		
14	Stop-lock-Cap	304		
15	Handle Nut (NPS 1/2 ~ NPS 2 1/2)	A194-8		
16	Lever (NPS 1/2 ~ NPS 2 1/2)	304		
17	Handle Sleeve	304		
18	Lock Device (NPS 1/2 ~ NPS 2 1/2)	304		
19	Body Gasket	PTFE / 316 Spiral Wound+Grafoil*		
20	Bolt Nut	A194-8	A194-2H	
21	Pipe Handle (NPS3 ~ NPS8)	A53+PLATED Zn		
22	Handle Adapter (NPS3 ~ NPS8)	A351-CF8		
23	Set Screwed (NPS3 ~ NPS8)	A2-70		
24	O-Ring	FKM		
25	Bolting (NPS3 ~ NPS8)	A2-70		
26	Stop Bolt	A2-70		
27	Nameplate	304		
28	Worm Gear (Optional)	Package		
29	Support Washer	304		
30	Stop Nut	A2-70		

*Materials for KV-L61, KV-L62 Series (Fire Safe Models)

Direct Mount Pad (ISO 5211)

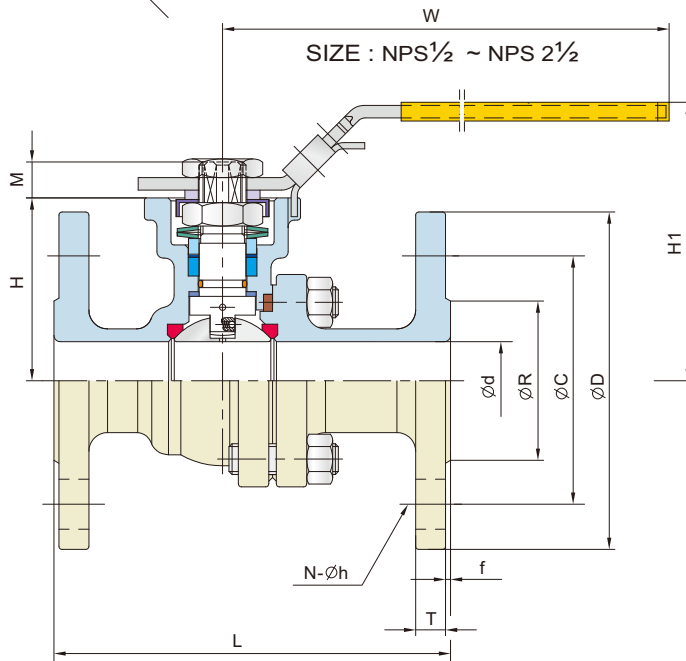
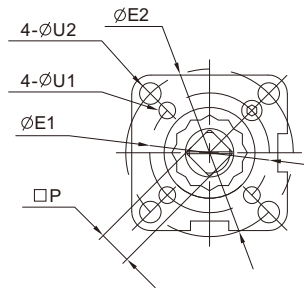

Pipe Handle Operation

SIZE : NPS 3 ~ NPS 8

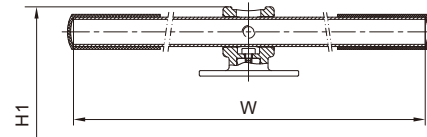

Gear Operation (Optional)

SIZE : NPS 2 1/2 ~ NPS 8

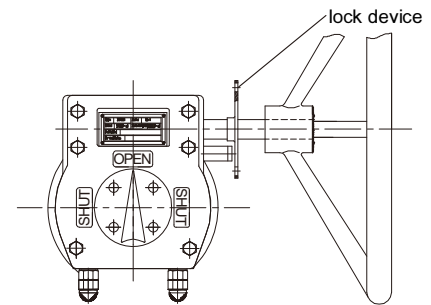

Automation (Optional)

SIZE : NPS 1/2 ~ NPS 8

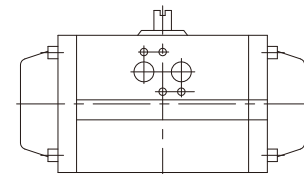

DIMENSION TABLE

ASME Class 150 DIMENSION TABLE KV-L41/KV-L61

Unit : mm

NPS	d	L	R	D	C	T	f	N	h	H	H1	W	P	M	E1	E2	U1	U2	ISO 5211
1/2	15	108	35.0	90	60.3	8.0	2	4	16.0	49	79	147	9	9	36	42	6	6	F03~F04
3/4	20	117	43.0	100	69.9	8.9	2	4	16.0	53	84	147	9	9	36	50	6	7	F03~F05
1	25	127	51.0	110	79.4	9.6	2	4	16.0	59	90	177	11	11	42	50	6	7	F04~F05
1 1/4	32	140	63.5	115	88.9	11.2	2	4	16.0	71	102	177	11	11	42	70	6	9	F04~F07
1 1/2	38	165	73.2	125	98.4	12.7	2	4	16.0	76	110	197	14	14	50	70	7	9	F05~F07
2	50	178	92.0	150	120.7	14.3	2	4	19.0	82	115	197	14	14	50	70	7	9	F05~F07
2 1/2	63.5	190	104.7	180	139.7	15.9	2	4	19.0	102	150	267	17	17	70	102	9	11	F07~F10
3	76	203	127.0	190	152.4	17.5	2	4	19.0	112	176	300	17	17	70	102	9	11	F07~F10
4	100	229	157.0	230	190.5	22.3	2	8	19.0	140	211	400	22	22	—	102	—	11	F10
5	125	356	186.0	255	215.9	22.3	2	8	22.3	183	263	600	27	27	125	—	14	—	F12
6	150	394	216.0	280	241.3	23.9	2	8	22.3	204	284	800	27	27	125	—	14	—	F12
8	200	457	270.0	345	298.5	27.0	2	8	22.3	253	334	800	27	27	125	140 ^(a)	14	18 ^(a)	F12orF14 ^(a)

ASME Class 150 DIMENSION TABLE KV-L41/KV-L61

Unit : inch

NPS	d	L	R	D	C	T	f	N	h	H	H1	W	P	M	E1	E2	U1	U2	ISO 5211
1/2	0.59	4.25	1.38	3.50	2.38	0.31	0.06	4	5/8	1.93	3.11	5.79	0.354	0.30	1.42	1.65	0.24	0.24	F03~F04
3/4	0.79	4.62	1.69	3.88	2.75	0.34	0.06	4	5/8	2.09	3.31	5.79	0.354	0.35	1.42	1.97	0.24	0.28	F03~F05
1	0.98	5.00	2.01	4.25	3.12	0.38	0.06	4	5/8	2.32	3.54	6.97	0.433	0.43	1.65	1.97	0.24	0.28	F04~F05
1 1/4	1.26	5.50	2.50	4.62	3.50	0.44	0.06	4	5/8	2.80	4.02	6.97	0.433	0.43	1.65	2.76	0.24	0.35	F04~F07
1 1/2	1.50	6.50	2.88	5.00	3.88	0.50	0.06	4	5/8	2.99	4.33	7.76	0.551	0.55	1.97	2.76	0.28	0.35	F05~F07
2	1.97	7.00	3.62	6.00	4.75	0.56	0.06	4	3/4	3.23	4.53	7.76	0.551	0.55	1.97	2.76	0.28	0.35	F05~F07
2 1/2	2.50	7.50	4.12	7.00	5.50	0.62	0.06	4	3/4	4.02	5.91	10.5	0.669	0.67	2.76	4.02	0.35	0.43	F07~F10
3	2.99	8.00	5.00	7.50	6.00	0.69	0.06	4	3/4	4.41	6.93	11.9	0.669	0.67	2.76	4.02	0.35	0.43	F07~F10
4	3.94	9.00	6.19	9.00	7.50	0.88	0.06	8	3/4	5.51	8.31	15.9	0.866	0.87	—	4.02	—	0.43	F10
5	4.92	14.00	7.32	10.00	8.50	0.88	0.06	8	7/8	7.20	10.35	23.7	1.063	1.06	4.92	—	0.55	—	F12
6	5.91	15.50	8.50	11.00	9.50	0.94	0.06	8	7/8	7.99	11.18	31.6	1.063	1.06	4.92	—	0.55	—	F12
8	7.87	18.00	10.63	13.50	11.75	1.06	0.06	8	7/8	9.96	13.15	31.6	1.063	1.06	4.92	5.51 ^(a)	0.55	0.71 ^(a)	F12orF14 ^(a)

(a):Optional

Direct Mount Pad (ISO 5211)

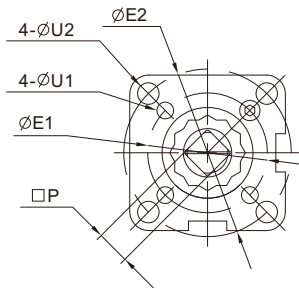

Pipe Handle Operation

SIZE : NPS 3 ~ NPS 8

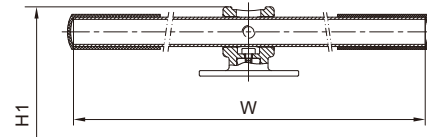

Gear Operation (Optional)

SIZE : NPS 2½ ~ NPS 8

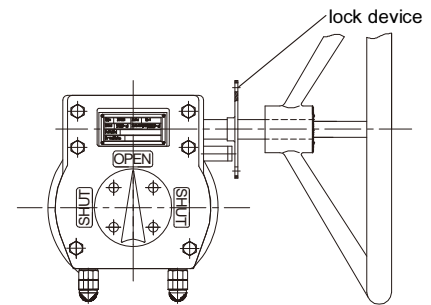

Automation (Optional)

SIZE : NPS ½ ~ NPS 8

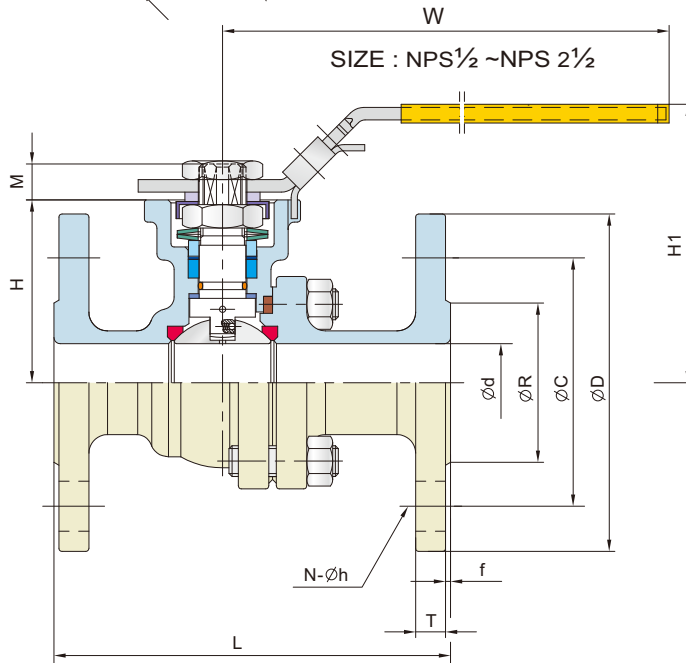
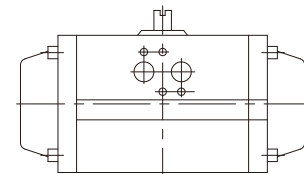

DIMENSION TABLE

ASME Class 300 DIMENSION TABLE KV-L42/KV-L62

Unit : mm

NPS	d	L	R	D	C	T	f	N	h	H	H1	W	P	M	E1	E2	U1	U2	ISO 5211
½	15	140	35.0	95	66.7	12.7	2	4	16.0	49	79	147	9	9	36	42	6	6	F03~F04
¾	20	152	43.0	115	82.6	14.3	2	4	19.0	59	89	147	9	9	36	42	6	6	F03~F04
1	25	165	51.0	125	88.9	15.9	2	4	19.0	64	95	177	11	11	42	50	6	7	F04~F05
1¼	32	178	63.5	135	98.4	17.5	2	4	19.0	71	102	177	11	11	42	50	6	7	F04~F05
1½	38	190	73.2	155	114.3	19.1	2	4	22.3	80	113	197	14	14	50	70	7	9	F05~F07
2	50	216	92.0	165	127.0	20.7	2	8	19.0	85	118	197	14	14	50	70	7	9	F05~F07
2½	63.5	241	104.7	190	149.2	23.9	2	8	22.3	102	150	267	17	17	70	102	9	11	F07~F10
3	76	282	127.0	210	168.3	27.0	2	8	22.3	112	176	300	17	17	70	102	9	11	F07~F10
4	100	305	157.0	255	200.0	30.2	2	8	22.3	140	211	400	22	22	—	102	—	11	F10
5	125	381	186.0	280	235.0	33.4	2	8	22.3	183	263	600	27	27	125	—	14	—	F12
6	150	403	216.0	320	269.9	35.0	2	12	22.3	204	284	800	27	27	125	—	14	—	F12
8	200	502	270.0	380	330.2	39.7	2	12	25.4	253	334	800	27	27	125	140 ^(a)	14	18 ^(a)	F12orF14 ^(a)

ASME Class 300 DIMENSION TABLE KV-L42/KV-L62

Unit : inch

SIZE	d	L	R	D	C	T	f	N	h	H	H1	W	P	M	E1	E2	U1	U2	ISO 5211
½	0.59	5.50	1.38	3.75	2.62	0.50	0.06	4	5/8	1.93	3.11	5.77	0.354	0.32	1.42	1.65	0.24	0.24	F03~F04
¾	0.79	6.00	1.69	4.62	3.25	0.56	0.06	4	¾	2.32	3.54	5.77	0.354	0.35	1.42	1.65	0.24	0.24	F03~F04
1	0.98	6.50	2.01	4.88	3.50	0.62	0.06	4	¾	2.52	3.74	6.95	0.433	0.43	1.65	1.97	0.24	0.28	F04~F05
1¼	1.26	7.00	2.50	5.25	3.88	0.69	0.06	4	¾	2.80	4.02	6.95	0.433	0.43	1.65	1.97	0.24	0.28	F04~F05
1½	1.50	7.50	2.88	6.12	4.50	0.75	0.06	4	7/8	3.15	4.49	7.75	0.551	0.55	1.97	2.76	0.28	0.35	F05~F07
2	1.97	8.50	3.62	6.50	5.00	0.81	0.06	8	¾	3.35	4.65	7.75	0.551	0.55	1.97	2.76	0.28	0.35	F05~F07
2½	2.50	9.50	4.12	7.50	5.88	0.94	0.06	8	7/8	4.02	5.91	10.50	0.669	0.67	2.76	4.02	0.35	0.43	F07~F10
3	2.99	11.12	5.00	8.25	6.62	1.06	0.06	8	7/8	4.41	6.93	11.90	0.669	0.67	2.76	4.02	0.35	0.43	F07~F10
4	3.94	12.00	6.19	10.00	7.88	1.19	0.06	8	7/8	5.51	8.31	15.80	0.866	0.87	—	4.02	—	0.43	F10
5	4.92	15.00	7.32	11.00	9.25	1.31	0.06	8	7/8	7.20	10.35	23.70	1.063	1.06	4.92	—	0.55	—	F12
6	5.91	15.88	8.50	12.50	10.62	1.38	0.06	12	7/8	8.03	11.18	31.60	1.063	1.06	4.92	—	0.55	—	F12
8	7.87	19.75	10.63	15.00	13.00	1.56	0.06	12	1	9.96	13.15	31.60	1.063	1.06	4.92	5.51 ^(a)	0.55	0.71 ^(a)	F12orF14 ^(a)

(a):Optional